

## General Safety Information

- Do not shut / open hinged doors with excessive force.
- Install door stop to prevent door from opening too far.
- When installing glass panels, ensure all staff are properly qualified and trained.
- Always wear protective clothing when mounting glass panels.
- Always allow and adjust for sufficient panel clearances so that the glass does not touch other parts such as metal, glass and concrete.
- Always use the required correct torque force when tightening mounting screws.
- Avoid creating local stress areas. Do not over tighten mounting screws. Do not use excessive force.

## Tools required for Hinge Adjustment:

- 11mm open-ended spanner
- 4mm Hex / Allen key (Preferably Ball-Nose)



## Installation:

### FRAME ATTACHMENT:

**IMPORTANT: DO NOT USE COUNTERSUNK CSK SCREWS FOR THE HINGE – TO – FRAME ATTACHMENT.**

- Attach the hinge to the frame first.
- Always use standard washers for M8 screws.
- Always use standard M8 Hex Bolts or standard Hex-Cap-Socket screws.
- Always tighten screws properly (12Nm(9ft-lb)).
- Always ensure that the frame structure is of suitable material and strength.

### DOOR ATTACHMENT:

- Attach door panel after the hinge has been mounted to the frame.
- Ensure that the door mount flanges are properly attached to the door panel before removing the support/lifting gear.
- All hinges are supplied in the mid-range adjustment position.
- When adjusting the door panel height, wind out the top height adjustment screws on both hinges before raising the panel height by winding in the bottom height adjustment screws on both hinges.
- When adjusting the door panel height, adjust both the top and bottom hinges to ensure the load is being shared equally by both.
- After the door has been height adjusted, wind back in the top adjustment screws on both hinges. **USE ONLY VERY SLIGHT FORCE (1NM / 0.8FT-LB). DO NOT OVER TIGHTEN THE TOP HEIGHT ADJUSTMENT SCREWS WHEN THE BOTTOMING OUT POSITION HAS BEEN REACHED.**
- Check all the hinges and fittings at regular intervals for correct positioning and adjustment.
- Use properly trained staff to inspect / maintain the proper condition of hinged doors, especially for frequently used panels.

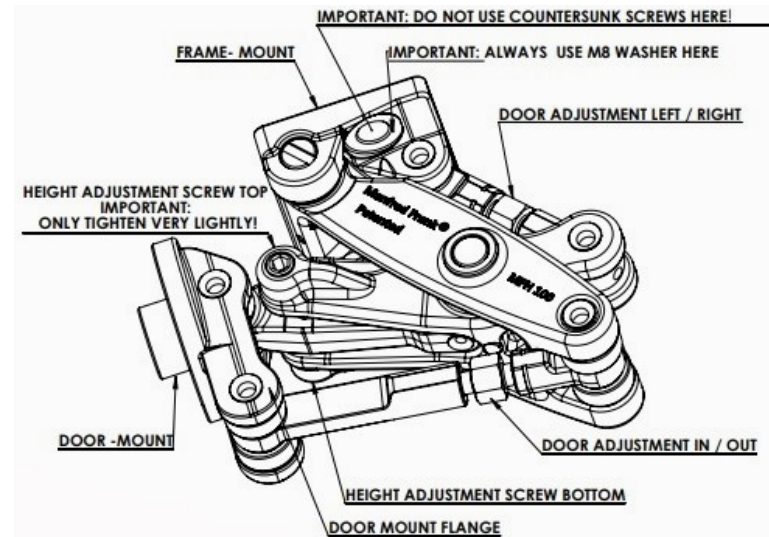

## Torque

Recommended tightening torque settings for screws:

- Monolithic, tempered (single panel) glass door = 12Nm (9ft – lb)
- Laminated, tempered (multiple panels) glass door = 12Nm (9ft – lb)
- Countersunk CSK glass screws = 12Nm (9ft – lb)
- Frame mount bolts = 12Nm (9ft – lb) if possible

We recommend using thread locking compound when possible.

## DISCLAIMER OF LIABILITY:

Since the conditions or methods of installation, operation, use and maintenance of this product are beyond its control; Manfred Frank Limited does not assume responsibility and expressly disclaims liability of loss, damage, or expense arising out of or in any way connected with such installation, operation, use or maintenance

**CONTACT & SUPPORT:**  
support@manfredfrank.com  
+64 9 272 3690  
www.manfredfrank.com



ROUTING GUIDES

FOR PANEL THICKNESS FROM 32MM (1.25") TO 51MM(2")

DOOR PANEL CUT OUT DETAILS  
FOR D50 & D51 DOOR MOUNTS

IMPORTANT: Please reference the cut out depth from the top panel surface.  
Ensure that the cut out depth is exact and does not change with panel thickness variations.

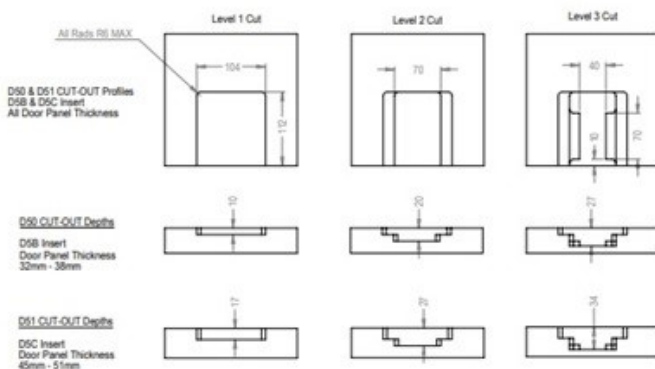
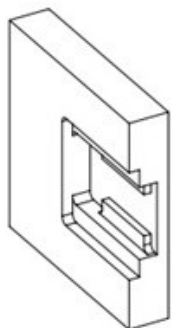

ADDITIONAL DETAILS FOR  
OVERLAY END DOOR PANEL  
CUT OUT FOR D50 & D51 DOOR MOUNTS

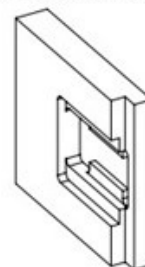

IMPORTANT: Please reference the cut out depth from the top panel surface.  
Ensure that the cut out depth is exact and does not change with panel thickness variations.

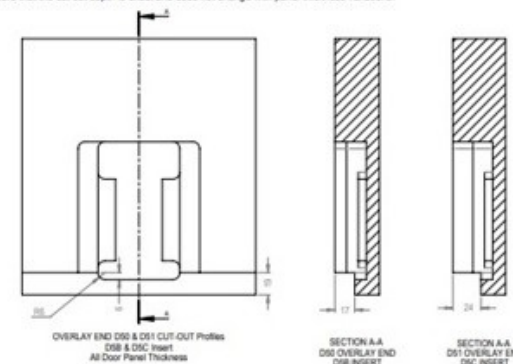

INSTALLATION

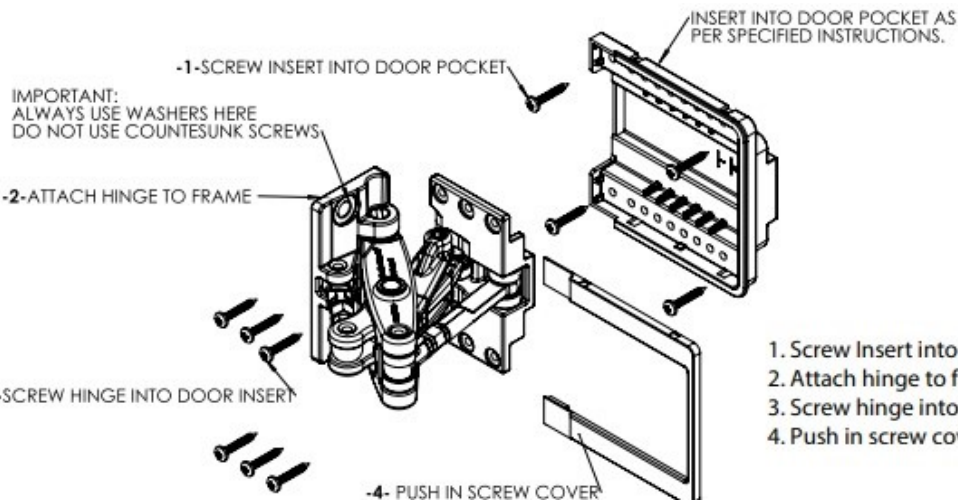

1. Screw Insert into door pocket
2. Attach hinge to frame
3. Screw hinge into door insert
4. Push in screw cover

DISCLAIMER OF LIABILITY:

Since the conditions or methods of installation, operation, use and maintenance of this product are beyond its control, Manfred Frank Limited does not assume responsibility and expressly disclaims liability of loss, damage, or expense arising out of or in any way connected with such installation, operation, use or maintenance

CONTACT & SUPPORT:  
support@manfredfrank.com  
+64 9 272 3690