

**CSK TO ENSURE M8 X 25 #316 CSK CAP IS ALWAYS BENEATH SURFACE
TIG WELD CSK HEAD IN PLACE (PARTIAL WELD SHOULD BE OK)**

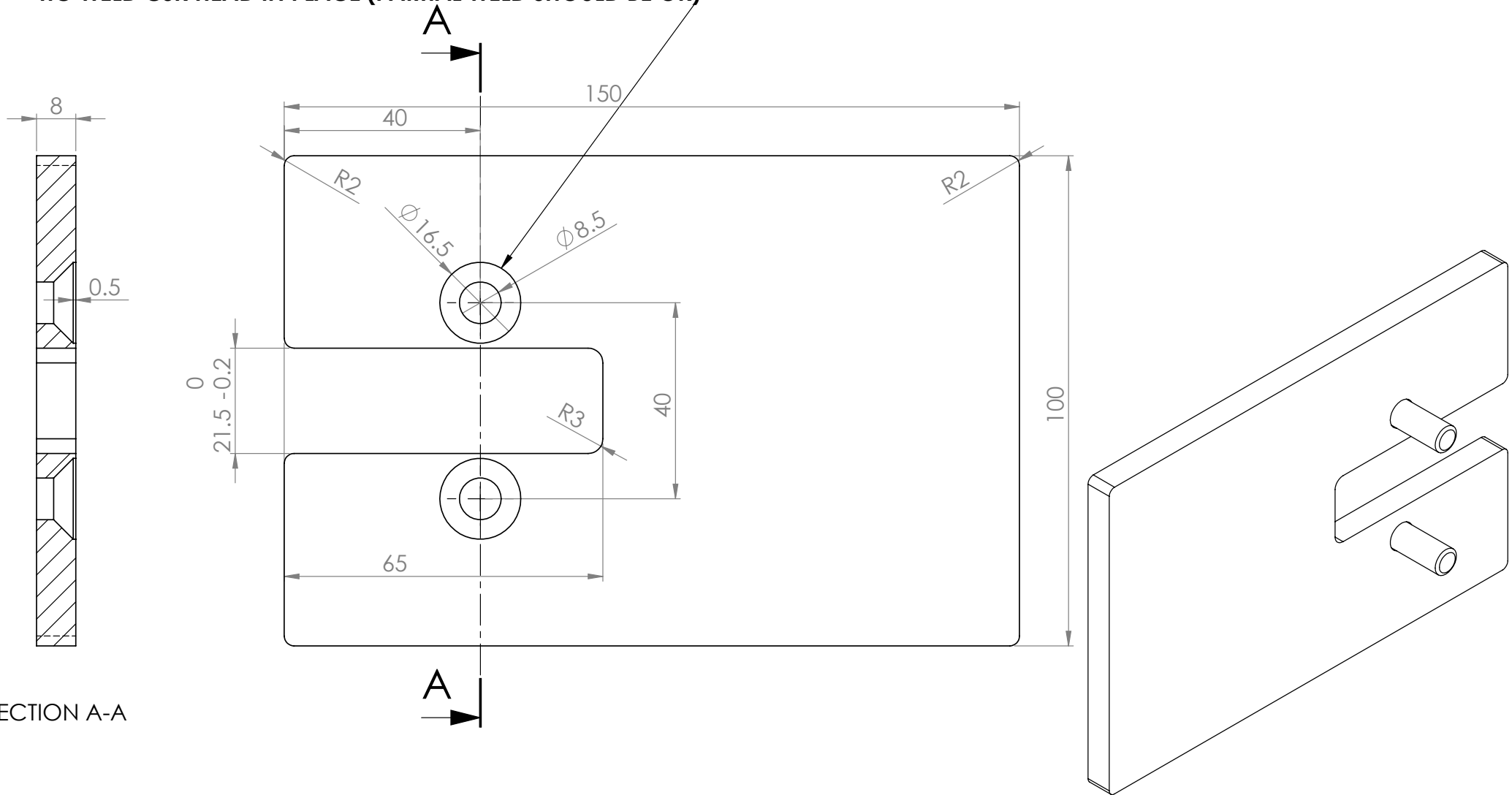

SECTION A-A

DISCLAIMER OF LIABILITY:

Since the conditions or methods of installation, operation, use and maintenance of this product are beyond its control, Manfred Frank Systems Limited does not assume responsibility and expressly disclaims liability of loss, damage, or expense arising out of or in any way connected with such installation, operation, use, or maintenance.

© Manfred Frank Systems Ltd.
All Rights Reserved.

CONTACT & SUPPORT:
support@manfredfrank.com
Manfred Frank Systems, Unit C, 11 Echelon Place, Botany 2013, Auckland, New Zealand
PO Box 259239, Botany 2163, Auckland, New Zealand
+64 9 272 3690